

About Lorbrand Material Solutions



Challenging the way things are done, we are delivering cost effective products and solutions to overcome excessive wear while reducing downtime and increasing productivity.

Some of our innovative products include: fast curing conveyor belt repair kits, proprietary bonded high density ceramic wear plate liners, advanced light weight composite structures, specialist adhesives and sealants, protective coatings and polyurethane castings.

A little bit about our conveyor belt repair kits:

Lorbrand's conveyor belt repair kits really do provide a simple, quick and cost-effective solution for anyone to repair and greatly extend the life of a damaged or torn conveyor belt.

Our repair kits are a two-part, 100% solids polyurethane compound for the repair of rubber (fabric and steel cord), Nitrile and PVC (solid woven) conveyor belts and linings.

Types of Repairs

- Skirt-line wear
- Tears / splits
- Mechanical fastener protection and concealing
- Spot
- Edge damage (including shark bite)
- Holes / punctures
- Splice

All products are manufactured in Australia.

Benefits

- Quick and easy application of product
- Fast cure times
- Can be used on a slope or angle – no sagging or slumping
- Suitable for a variety of repairs
- Can be reused after use – no wastage
- Local service and support
- No hand mixing required
- Safer – no requirement for complex or heavy equipment
- No requirement for special permit

	Qik Fix	Rapid Repair	FRAS Repair
Cure Time	30 minutes	2 Hours	30 minutes
Workable Time	10 – 12 minutes	15 minutes	10 – 12 minutes
Kit Size	1050g (37oz)	600g and 1.5kg (21oz and 53oz)	1050g (37oz)
Shore Hardness	80 – 85A	60 – 65A	80 – 85A
Applicator	Pneumatic Caulking Gun / Hand Held Caulking Gun	Pneumatic Caulking Gun/ Hand Held Caulking Gun	Pneumatic Caulking Gun/ Hand Held Caulking Gun
Primer	Primer No.6 / 11 (Rubber)	Primer No.6 / 11 (Rubber)	Primer No.6 / 11 (Rubber)
Skirtline Damage	✓	✓	✓
Hole/Puncture Repair	✓	✓	✓
Split Repair	✓	✓	✓
Edge Repair	✓	✓	✓
Splice Repair	✓	✓	✓
Mechanical Fastener	✓	✓	✓



QIK FIX CONVEYOR BELT REPAIR KIT (1050G)

Qik Fix is a fast curing, 30-minute, two-part 100% solids polyurethane conveyor belt repair kit which is used for the repair of fabric, steel cord and PVC conveyor belts.

Qik Fix has been specifically engineered to be a high performance conveyor belt repair product, offering superior adhesion strength and excellent abrasion and tear resistance.

Qik Fix is applied with either a manual or pneumatic caulking gun and self-mixing nozzle, ensuring the product is thoroughly mixed at the correct ratio (there is no need for hand mixing). Once applied to the conveyor belt, it has a working time of 10-12 minutes (at 24°C). The high viscosity of Qik Fix allows it to be applied on a belt on an incline or conveyor troughs of up to 50° without sagging or slumping.

Completing a repair with Qik Fix provides an engineering grade bond to the substrate, thus increasing the life of the belt with minimal downtime.

Colour: Black	Working time: 10 - 12 min at 24°C	Shelf life: 12 months @ 22°C (72°F)
Shrinkage: <1%	Hardness: 80 - 85A	Return belt to service: after 4 hrs @ 24°C (75°F)



RAPID REPAIR CONVEYOR BELT REPAIR KIT (600G / 1.5KG)

Rapid repair is a 2-hour curing, two-part 100% solids polyurethane conveyor belt repair kit that is used for the repair of fabric, steel cord and PVC conveyor belts.

Rapid Repair has been specifically engineered to be a high performance conveyor belt repair product that matches the hardness of the rubber belt.

Rapid Repair is applied with either a manual or pneumatic caulking gun and self-mixing nozzle, ensuring the product is thoroughly mixed at the correct ratio (there is no need for hand mixing). Once applied to the conveyor belt, it has a working time of 15 minutes (at 24°C). The high viscosity of Rapid Repair allows it to be applied on a belt on an incline or conveyor troughs of up to 50° without sagging or slumping.

Completing a repair with Rapid Repair provides an engineering grade bond to the substrate, thus increasing the life of the belt with minimal downtime.

Colour: Black	Working time: 15 min at 24°C	Shelf life: 12 months @ 22°C (72°F)
Shrinkage: <1%	Hardness: 60 - 65A	Return belt to service: after 6 hrs @ 24°C (75°F)



FRAS BELT REPAIR KIT (1050G)

FRAS repair is a new fast curing, 30 minute, two-part 100% solids polyurethane conveyor belt repair kit that is used for the underground repair of fabric, steel cord and PVC conveyor belts.

This fire retardant and anti static (FRAS) repair kit has been specifically engineered and is compliant with the requirements of MDG 3608 for use in underground mines.

FRAS Repair is applied with either a manual or pneumatic caulking gun and self-mixing nozzle, ensuring the product is thoroughly mixed at the correct ratio (there is no need for hand mixing). Once applied to the conveyor belt, it has a working time of 10-12 minutes (at 24°C). The high viscosity of FRAS Repair allows it to be applied on a belt on an incline or conveyor troughs of up to 50° without sagging or slumping.

Completing a repair with FRAS Repair provides an engineering grade bond to the substrate, thus increasing the life of the belt with minimal downtime.

Colour: Grey/Black	Working time: 10-12 min at 24°C	Shelf life: 12 months @ 22°C (72°F)
Shrinkage: <1%	Hardness: 80 - 85A	Return belt to service: after 4 hrs @ 24°C (75°F)



PRIMER NO.3 (POLYURETHANE)

Primer No.3 is a two-part polyurethane primer used for bonding Lorbrand's Qik Fix Conveyor Belt Repair Kit to an already fully cured repair

Colour: Honey
Number of Coats: 1 coat
Drying Time: 60 minutes
Shelf life: 12 months @ 22°C (72°F)



PRIMER NO.6 (RUBBER)

Primer No. 6 is a two-part rubber primer used for bonding Lorbrand's Qik Fix Conveyor Belt Repair Kit to natural and certain synthetic rubbers.

Colour: Dark Grey
Number of Coats: 2 coats
Drying Time: 45 minutes
Shelf life: 12 months @ 22°C (72°F)



PRIMER NO.11 (RUBBER)

Primer No. 11 is a single part rubber primer used for bonding Lorbrand's Qik Fix Conveyor Belt Repair Kit to natural and certain synthetic rubbers.

Colour: Clear
Number of Coats: 1 coat
Drying Time: 45 minutes
Shelf life: 12 months @ 22°C (72°F)

Accessories

MANUAL CAULKING GUN

This heavy-duty manual caulking gun is used to dispense Lorbrand's Conveyor Belt Repair Kit. Ideally suited for small repairs.



PNEUMATIC CAULKING GUN

This durable pneumatic caulking gun is used to easily dispense Lorbrand's Conveyor Belt Repair Kits. Ideally suited for large repairs.



APPLICATORS

Lorbrand's range of scraper blades are ideal for applying Lorbrand's Conveyor Belt Repair Kit to achieve a smooth and even finish to a repair.



Step 1

Prepare surface – clean and grind out the repair area with a wire brush/wheel. Ensure a profile in the rubber is produced.



Step 2

Clean the surface – use Acetone, Perchloroethylene (PERT) or MEK solution with a clean plain white rag to thoroughly clean the surface.

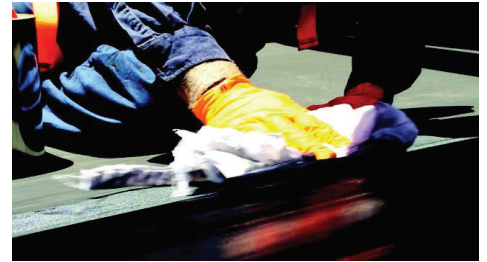

Step 3

Prime the surface – thoroughly mix and brush on 2 separate coats of Lorbrand Primer No.6 – allow 20 – 45 minutes drying time on the 1st coat and then apply a second coat.

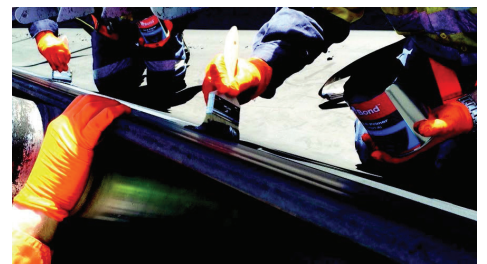

Step 4

Repair the surface – once the second coat of the Primer No.6 is tacky, fill the repair area using Lorbrand's conveyor repair kit.



Step 5

Finish the surface – use a scraper blade to smooth out the material to the repair area and feather out the edges (no need to buff once completed).



SKIRT-LINE DAMAGE REPAIR

Step 1

Prepare Surface – clean and buff the repair area with a wire brush/wheel. Ensure a profile in the rubber is produced and a rounded profile with no sharp edges or corners as per figure 1.

Step 2

Clean the surface – using a clean plain white rag, use Acetone, Perchloroethylene (PERT) or MEK solvent to thoroughly clean the area for repair.

Step 3

Prime the surface – thoroughly mix and brush on 2 separate coats of Lorbrand's Primer No.6. Depending on the ambient temperature, allow 20 - 45 minutes drying time on the 1st coat before then applying a second coat.

Step 4

Repair the surface – once the second coat of Lorbrand's Primer No.6 is tacky, fill the repair area using Lorbrand's conveyor belt repair kit. Note: Ensure part A of the kit has the appropriate viscosity (i.e. the bubble in part A moves freely when tilted back and forth at a 45 degree angle).

Step 5

Finish the repair – use a scraper blade to smooth out the material to the repair area (as per figure 2) and feather out the edges (there is no need to buff the repair once completed).

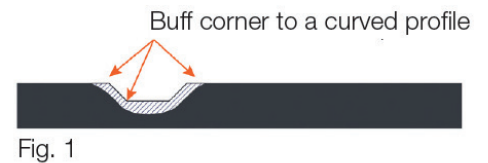
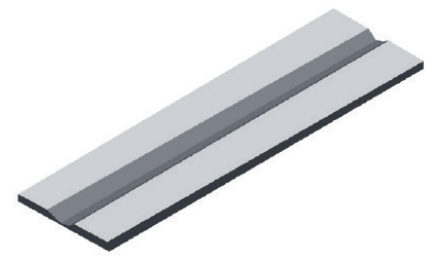

PUNCTURE OR HOLE REPAIR

Step 1

Cut the top and bottom jagged edge of the puncture or hole with a knife as per figure 3.

Step 2

Prepare Surface - clean and buff the repair area with a wire brush/wheel. Ensure a profile in the rubber is produced and a rounded profile with no sharp edges or corners as per figure 4.

Step 3

Clean the surface – using a clean plain white rag, use Acetone, Perchloroethylene (PERT) or MEK solvent to thoroughly clean the area for repair.

Step 4

Prime the surface – thoroughly mix and brush on 2 separate coats of Lorbrand's Primer No.6. Depending on the ambient temperature, allow 20 - 45 minutes drying time on the 1st coat before then applying a second coat.

Step 5

Apply and secure backing or base plate of melamine, aluminum under repair as per figure 4. Note: Ensure the melamine or aluminum is either waxed or has been covered in packing tape. This will ensure the release of the plate.

Step 6

Repair the surface – once the second coat of Lorbrand's Primer No.6 is tacky, fill the repair area using Lorbrand's conveyor belt repair kit, ensuring to inject it in to the underneath edge of the repair. Note: Ensure part A of the kit has the appropriate viscosity (i.e. the bubble in part A moves freely when tilted back and forth at a 45 degree angle).

Step 7

Finish the repair – use a scraper blade to smooth out the material to the repair area (as per figure 5) and feather out the edges (there is no need to buff the repair once completed). Once cured, remove the backing plate.

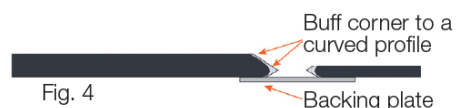
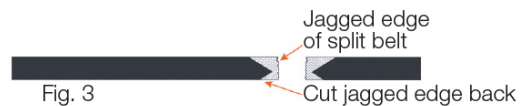
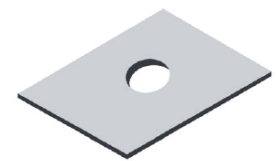

SPLIT REPAIR

Step 1

Cut the top and bottom jagged edge of split with a knife as per figure 6.

Step 2

Prepare Surface – clean and buff the repair area with a wire brush/wheel. Ensure a profile in the rubber is produced and a rounded profile with no sharp edges or corners as per figure 7.

Step 3

Clean the surface – using a clean plain white rag, use Acetone, Perchloroethylene (PERT) or MEK solvent to thoroughly clean the area for repair.

Step 4

Prime the surface – thoroughly mix and brush on 2 separate coats of Lorbrand's Primer No.6. Depending on the ambient temperature, allow 20 - 45 minutes drying time on the 1st coat before then applying a second coat.

Step 5

Apply and secure backing or base plate of melamine, aluminum under repair as per figure 7.

Step 6

Repair the surface – once the second coat of Lorbrand's Primer No.6 is tacky, fill the repair area using Lorbrand's conveyor belt repair kit, ensuring to inject it in to the underneath edge of the repair. Note: Ensure part A of the kit has the appropriate viscosity (i.e. the bubble in part A moves freely when tilted back and forth at a 45 degree angle).

Step 7

Finish the repair – use a scraper blade to smooth out the material to the repair area (as per figure 8) and feather out the edges (there is no need to buff the repair once completed). Once cured, remove the backing plate.

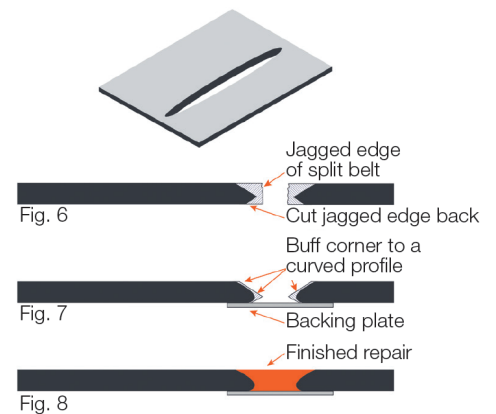

EDGE REPAIR

Step 1

Cut the top and bottom jagged edge of the belt with a knife as per figure 9.

Step 2

Prepare Surface - clean and buff the repair area with a wire brush/wheel. Ensure a profile in the rubber is produced and a rounded profile with no sharp edges or corners as per figure 10.

Step 3

Clean the surface – using a clean plain white rag, use Acetone, Perchloroethylene (PERT) or MEK solvent to thoroughly clean the area for repair.

Step 4

Prime the surface – thoroughly mix and brush on 2 separate coats of Lorbrand's Primer No.6. Depending on the ambient temperature, allow 20 - 45 minutes drying time on the 1st coat before then applying a second coat.

Step 5

Apply and secure the aluminum mould under repair as per figure 11. Note: Ensure the aluminum mould is either waxed or has been covered in packing tape. This will ensure the release of the plate.

Step 6

Repair the surface – once the second coat of Lorbrand's Primer No.6 is tacky, fill the repair area using Lorbrand's conveyor belt repair kit, ensuring to inject it in to the underneath edge of the repair. Note: Ensure part A of the kit has the appropriate viscosity (i.e. the bubble in part A moves freely when tilted back and forth at a 45 degree angle).

Step 7

Finish the repair – use a scraper blade to smooth out the material to the repair area (as per figure 11) and feather out the edges (there is no need to buff the repair once completed). Once cured, remove the mould.

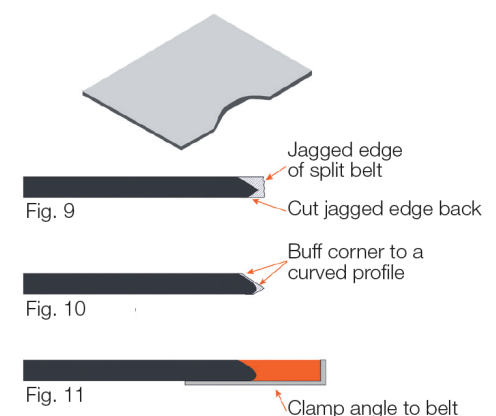

MECHANICAL FASTENER PROTECTION

Step 1

Prepare Surface – cut the belt and skive top cover down to the first layer of ply as per figure 12. Buff the skived area with a wire brush/wheel. Ensure a profile in the rubber is produced and a rounded profile with no sharp edges or corners as per figure 13.

Step 2

Install the fastener / clip as per manufactures instructions.

Step 3

Clean the surface – using a clean plain white rag, use Acetone, Perchloroethylene (PERT) or MEK solvent to thoroughly clean the area for repair.

Step 4

Prime the surface – thoroughly mix and brush on 2 separate coats of Lorbrand's Primer No.6, this can be used on the steel fastener / clip. Depending on the ambient temperature, allow 20 - 45 minutes drying time on the 1st coat before then applying a second coat.

Step 5

Repair the surface – once the second coat of Lorbrand's Primer No.6 is tacky, fill conveyorbelt repair kit. Note: Ensure part A of the kit has the appropriate viscosity (i.e. the bubble in part A moves freely when tilted back and forth at a 45 degree angle).

Step 6

Finish the repair – use a scraper blade to smooth out the material to the repair area (as per figure 14) and feather out the edges (there is no need to buff the repair once completed).

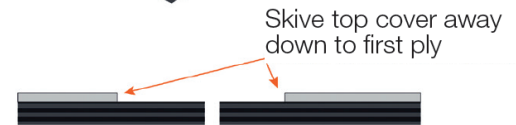
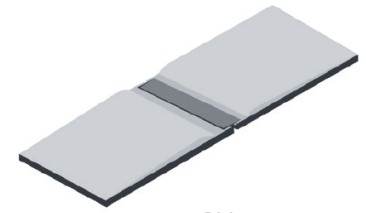

Fig. 12

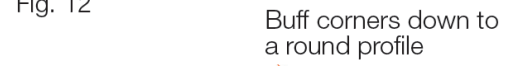

Fig. 13

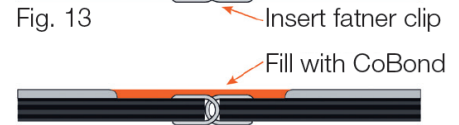

Fig. 14



SKIRT-LINE DAMAGE REPAIR

Step 1

Prepare Surface – clean and buff the repair area with a wire brush/wheel. Ensure a profile in the rubber is produced and a rounded profile with no sharp edges or corners as per figure 1.

Step 2

Clean the surface – using a clean plain white rag, use Acetone, Perchloroethylene (PERT) or MEK solvent to thoroughly clean the area for repair.

Step 3

Prime the surface – thoroughly mix and brush on 2 separate coats of Lorbrand's Primer No.6. Depending on the ambient temperature, allow 20 - 45 minutes drying time on the 1st coat before then applying a second coat.

Step 4

Repair the surface – once the second coat of Lorbrand's Primer No.6 is tacky, fill the repair area using Lorbrand's conveyor belt repair kit. Note: Ensure part A of the kit has the appropriate viscosity (i.e. the bubble in part A moves freely when tilted back and forth at a 45 degree angle).

Step 5

Finish the repair – use a scraper blade to smooth out the material to the repair area (as per figure 2) and feather out the edges (there is no need to buff the repair once completed).

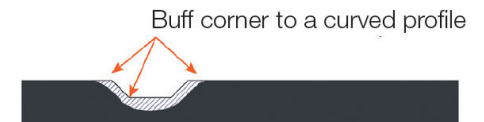
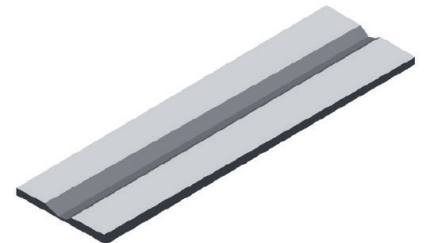

Fig. 1



Fig. 2

Finished repair

REPAIR: 146 metre skirt-line damage conveyor belt repair

PRODUCT: Lorbrand Qik Fix / Primer No.6 / Primer No.3

LOCATION: New South Wales

MATERIAL: Coal

SITUATION: A large rock was lodged between the hard skirt and the belt for a period of time. As a result, this wore a 100mm (W) x 12mm (D) groove along the entire length of the belt down to the steel cables.



RESULT: Estimate cost to replace the steel cable belt - \$270,000

Cost to repair the belt - \$35,000

Saving - \$235,000

Importantly, the repairs were performed during planned maintenance windows, allowing the belt to remain in service without any issues for a further 16 months until the normal replacement date.

REPAIR: Spot / puncture repair

PRODUCT: Lorbrand Rapid Repair / Primer No.6

LOCATION: New South Wales

MATERIAL: Coal

SITUATION: A material loading facility had 40 spot / puncture repairs to the boom conveyor as a result of material being caught in between the pulley and the conveyor belt.

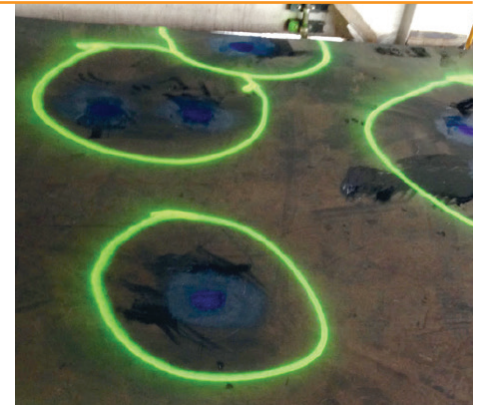

RESULT: Cost to repair the belt - \$4,500

The repairs were performed during a planned maintenance window, allowing the belt to remain in service without any issues.

REPAIR: 60 metre skirt-line damage conveyor belt repair

PRODUCT: Lorbrand Qik Fix / Primer No.6 / Primer No.3

LOCATION: Western Australia

MATERIAL: Iron Ore

SITUATION: A hard skirt had damaged the belt. As a result, this wore a 180mm (W) x 10mm (D) groove along the entire length of the belt.

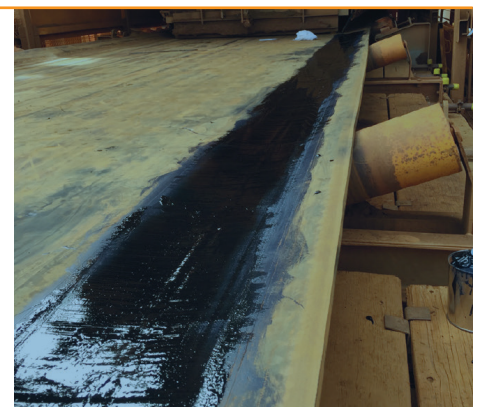

RESULT: Estimate cost to replace the steel cable belt - \$350,000

Cost to repair the belt - \$58,000

Saving - \$292,000

Importantly, the repairs were performed during a planned maintenance window. The repair enabled the belt to remain in service for a further 12 months.



Management
Systems
ISO 9001:2008

www.tuv.com
ID 1100000594

Address: C3, 20 Tarlton Cres, Perth Airport WA 6105

Postal Address: PO Box 602, North Perth, WA 6906

Phone Number: 1300 70 70 67

Email: sales@lorbrand.com.au

Web: lorbrand.com.au